



# ZLIM42

## Integrated Open Loop Step Motor Manual(PULSE CONTROL)

【 Please read the manual in detail before use, to avoid damage to the motor】



---

### Shenzhen ZhongLing Technology Co.,Ltd.

Add: 8th Floor, Building 3, Qiyu Industrial City, Gongle Tiezai Rd., Xixiang St., Bao'an Dist, Shenzhen, China

Postcode: 518102

Tel: +86-0755-2979 9302

Fax: +86-0755-2912 4283

Email: sales@zlingkj.com

Web: www.zlingkj.com

# CONTENTS

**PREFACE.....3**

**SAFETY PRECAUTIONS.....3**

**1. PRODUCT INTRODUCTION .....7**

    1.1 OUTLINE ..... 7

    1.2 FEATURES..... 7

    1.3 APPLICATION ..... 8

**2. ELECTRICAL, ENVIRONMENTAL INDEX.....8**

    2.1 ELECTRICAL INDEX..... 8

    2.2 ENVIROMENTAL INDEX ..... 8

    2.3 INSTALLATION DIAGRAM ..... 9

    2.4 INSTALLATION..... 9

**3. DRIVER INTERFACE AND WIRING..... 10**

    3.1 INTERFACE DEFINITION..... 10

    3.2 CONTROL SIGNAL WIRING..... 11

    3.3 OUTPUT SIGNAL WIRING..... 13

    3.4 STATUS INDICATOR LED..... 13

**4. DIP SWITCH SETTING ..... 14**

    4.1 STEP RESOLUTION SETTING..... 14

    4.2 MOTOR ROTATION DIRECTION SETTING ..... 15

# RELEASE NOTES:

Version	Update time	Update Content	Updater
V1.00	2018-10-12	First edition	LHY
V1.01	2019-9-28	<ol style="list-style-type: none"> <li>1. Add wiring precaution in PREFACE;</li> <li>2. Add motor output holding torque in Chapter 2.1;</li> <li>3. Add mechanical installation drawing in Chapter 2.3;</li> <li>4. Modify step resolution in Chapter 3.1.2.</li> </ol>	LHY
V1.02	2020-4-2	<ol style="list-style-type: none"> <li>1. Update P/N from ZLIM42-P to ZLIM42</li> </ol>	LHY
V1.03	2021-1-6	<ol style="list-style-type: none"> <li>1. Update the power supply voltage range in Chapter 1.2 and Chapter 2.1;</li> <li>2. Update power input port in Chapter 3.1.1;</li> <li>3. Revise the subdivision description in Chapter 1.2 and Chapter 3.1.2;</li> <li>4. Modify the interface content of in Chapter 1.2, Chapter 3.1.3 and Chapter 3.2 for hardware version is above V1.2.</li> </ol>	LHY

## PREFACE

Thanks for choosing ZLIM42, the integrated open loop stepper motor.

This manual describes the installation, debugging, maintenance, operation and other aspects of the integrated open loop stepper motor ZLIM42. Please read this manual in detail before use, and be familiar with the safety precautions.

This manual may be revised timely when product is improved, specification and version are changed or for some other reasons, which will not be notified particularly.

Any questions when using our products, please read the relevant manual or call our technical service department, we will meet your requirements in the shortest possible time.

### Marks and warning signal:



**Danger:** Indicates that this operation error may endanger personal safety!



**Attention:** Indicates that this operation error may result in equipment damage!

## SAFETY PRECAUTIONS

### Open Box and Check



Do not install integrated step-servo motor which is damaged or with missing parts.

### Installation



Installed on a non-flammable metal frame, prevent the intrusion of

dust, corrosive gases, conductive objects, liquids and flammable materials, and maintain good heat dissipation conditions.



During installation, be sure to tighten the mounting screws of the integrated step-servo motor. It should be protected from vibration and shock.

### Wiring



Please perform the wiring work by professional electrical engineer;



Before wiring, please confirm that the input power is off. Wiring and inspection must be performed after the power is turned off and the integrated step-servo motor indicator is off to prevent electric shock;



When plugging and unplugging the integrated step-servo motor terminals, make sure that its indicator is off before proceeding;



Please set the emergent stop circuit outside the controller;



Please tighten the output terminal with a suitable torque.

### Electrify



Please confirm whether the main circuit input power is consistent with the rated working voltage of the integrated step-servo motor;



Do not test the integrated step-servo motor for high voltage and insulation resistance at will;



Do not connect the electromagnetic contactor or electromagnetic switch to the output circuit.

### Operation



Do not directly touch the output terminals after the integrated step-servo motor is powered on;



When the system is running, the integrated step-servo motor may

have a high temperature rise, do not touch it;

 Please confirm the input and output signals to ensure safe operation;

 The alarm can be reset only after the operation signal is cut off. Alarm resetting in the running signal state will cause the integrated step-servo motor to restart suddenly;

 Do not change the parameter settings of the integrated step-servo motor at will. The parameter modification needs to be performed under standby condition.

### Maintenance and Inspection

 Do not touch the integrated step-servo motor terminals directly, and some have high voltage, very dangerous;

 Before powering up, be sure to install the cover; when removing the cover, be sure to cut off the power supply first;

 Before wiring, please confirm whether the input power is off;

 After cutting off the main circuit input power and confirming the integrated step-servo motor indicator light has completely extinguished, it can be inspected and maintained;

 Do the inspection and maintenance by professional electrical engineer;

 Do not do wiring, disassembling or other operation on the terminals during power on.

 Have a designated professional electrical engineer perform the inspection and maintenance work;

 During power-on, do not perform any work such as wiring or removing terminals.

 There is an integrated circuit on the main control board of the

integrated step-servo motor. Please pay full attention when checking to avoid damage caused by static induction.

# 1. PRODUCT INTRODUCTION

## 1.1. Outline

ZLIM42 is a 2 phase hybrid open loop motor with high-performance digital integrated drive. The system has a simple structure and high integration. This series of integrated open loop stepper motor uses the latest 32-bit dedicated DSP chip for motor control, advanced digital filter control technology, resonance vibration suppression technology and precise current control technology to ensure the 2 phase hybrid stepper motor run accurately and stably. This series of integrated open loop stepper motor has characteristics of high output torque, low noise, low vibration, and low heat, which is especially suitable for electronic processing equipment, laser processing machine, medical and small digital control equipment.

## 1.2. Features

- Ultra-low vibration and noise;
- Maximum 256 microstep subdivision, minimum unit 1;
- Input voltage: 18V-26VDC;
- 3 Isolated differential signal input: 3.3-24VDC;
- 1 isolated output port: alarm output, OC;
- 4 DIP switch selection, 16-segment step resolution, default step resolution 1-256, can be customized according to customer;
- Automatic flow reduction function: 50%;
- With over-voltage, over-current, over-differential protection functions.

## 1.3. Application

Suitable for all kinds of small automation equipment and instruments, such as: pneumatic marking machine, labeling machine, cutting machine, laser marking machine, plotter, small engraving machine, CNC machine tool, pick and place device. It is particularly effective in applications where users expect low noise, low vibration, high stationarity and high precision.

# 2. ELECTRICAL, ENVIRONMENTAL INDEX

## 2.1. Electrical Index

Driver Parameter		Min value	Typical value	Max value	Unit
Input voltage		18 VDC	24VDC	36VDC	V
Output current(peak)		0	1.2	2	A
Step signal frequency		0	-	200k	Hz
Control signal input current		7	10	16	mA
Over-voltage protection		-	50	-	VDC
Input signal voltage		-	5	-	VDC
Insulation resistance		100			MΩ
Holding torque	L=70mm		0.48		N.m
	L=82mm		0.72		

## 2.2 Environmental Index

Cooling Type		Natural cooling or forced cooling
Working environment	Application occasion	Avoid dust, oil mist and corrosive gases
	Working temperature	0~50°C
	Max. ambient humidity	90% RH (no condensation)
	Storage temperature	-10~70°C
	Vibration	10~55Hz/0.15mm

## 2.3 Installation Diagram

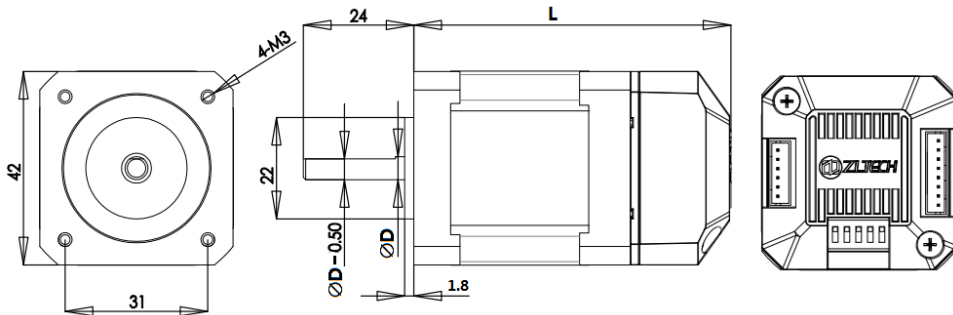

Fig.1 Installation dimension diagram (Unit: mm)

There are 2 options for L:70mm, 82mm. 2 options for  $\varnothing D$ : 5mm, 8mm.

## 2.4 Installation

User could mount with the mounting holes on the front of the integrated step-servo motor. Use M3 screw to install through the holes in the four corners. The integrated step-servo motor will generate heat. If continuous operation is under high input voltage and high power conditions, the effective heat dissipation area or forced cooling should be expanded. Do not use in places where air is not circulating or where the ambient temperature exceeds 60°C; do not install it in a place that is wet or has metal shavings.

## 3. DRIVER INTERFACE AND WIRING

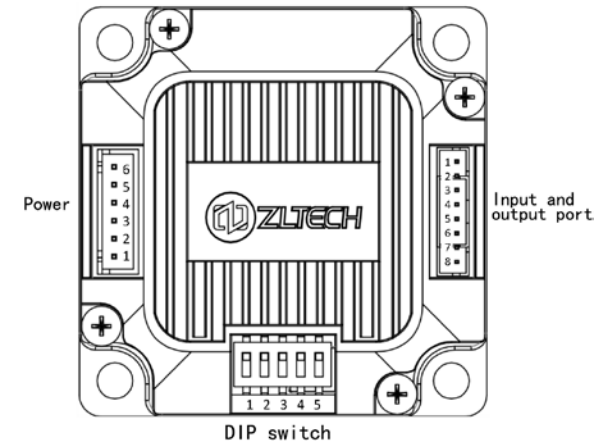

### 3.1 Interface Definition

#### 3.1.1 Power input port

Port	Pin	Mark	Name	Function
	6	DC	Power interface	Power supply 18-36V
	5	GND		
	4	NC	Floating interface	Normal: NC
	3	NC		
	2	NC		
	1	NC		

#### 3.1.2 DIP switch

Port	Pin	Mark	Name	Function
	1	SW1	DIP switch	Motor direction selection
	2	SW2		Step resolution setting; Default value 1-256; Could be customized according to customer's demand.
	3	SW3		
	4	SW4		
	5	SW5		

### 3.1.3 Control signal port

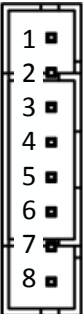
Port	PIN	Mark	Name	Function
	1	PUL+	Pulse input	The default input voltage is 5V. For other voltages, current limiting resistors must be added, for example: 12V, external 1K 1 / 2W resistor, 24V, external 2K 1 / 2W resistor.
	2	PUL-		
	3	DIR+	Direction input	The default input voltage is 5V. For other voltages, current limiting resistors must be added, for example: 12V, external 1K 1 / 2W resistor, 24V, external 2K 1 / 2W resistor.
	4	DIR -		
	5	ENA+	Enable input	The default input voltage is 5V. For other voltages, current limiting resistors must be added, for example: 12V, external 1K 1 / 2W resistor, 24V, external 2K 1 / 2W resistor.
	6	ENA-		
	7	ALM+	Alarm input	Optically isolated OC output
	8	ALM-		

### 3.2 Control Signal Wiring

If input control signal is differential, its control signal interface wiring diagram is shown in Figure 2.

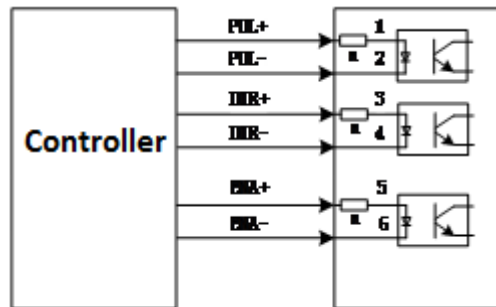

Fig.2 Control signal interface wiring diagram

If input control signal single-ended, its control signal interface wiring diagram is shown in Figure 3:

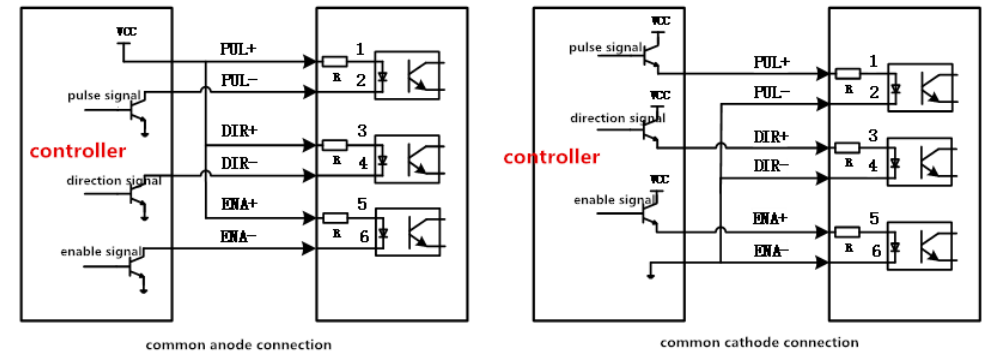

Fig.3 Input interface circuit

Note: The default input voltage of the control signal is 3.3-24V. For other voltages, current limiting resistors must be added. For example: 12V, external 1K 1 / 2W resistor; 24V, external 2K 1 / 2W resistor.

### Control signal timing diagram

In order to avoid some malfunctions and deviations, PUL, DIR and ENA should meet certain requirements, as shown in the figure below:

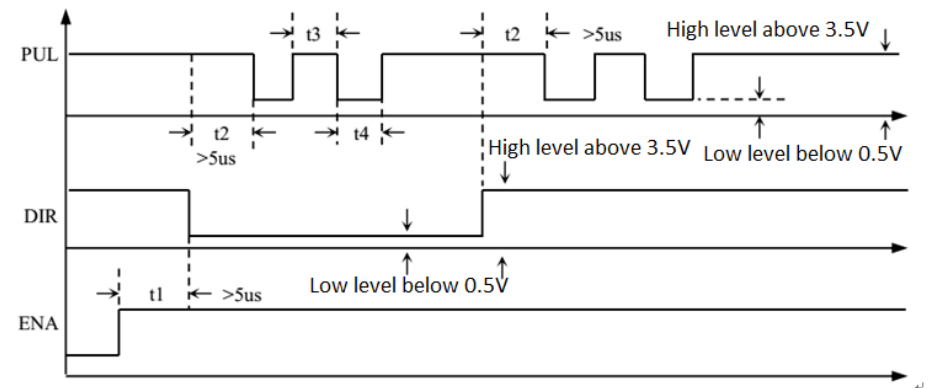

Fig.4 Control signal timing diagram

Note:

- t1: ENA (enable signal) should be confirmed to be high at least 100ms ahead of DIR, to ensure that the brake is open, and the motor enters running state, to avoid

abnormality.

- 2) t2: DIR is confirmed for its state to be high or low at least 5μs ahead of PUL falling edge.
- 3) t3: The pulse width is at least not less than 2.5μs.
- 4) t4: The low level width is not less than 2.5μs.

### 3.3. Output Signal Wiring

Signal output wiring, such as alarm signal output ALM, photoelectric isolation OC output, the highest withstand voltage 30VDC, the maximum saturation current 50mA.

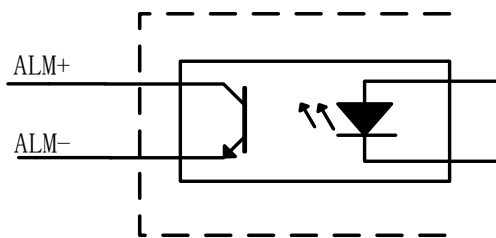

Fig.5 Output Signal Wiring

### 3.4. Status Indicator LED

The green LED is the power indicator, which is always on when the driver is powered up; it is off when the driver is powered off. The red LED is the fault indicator. When the driver fails, it will stop and prompt the corresponding fault code. The fault can be cleared when the user needs to power off and restart the power. The status indicator LED represents different operation and fault information, as shown in the following table:

Status	Condition	Status indicator LED description	
over-voltage	Power supply voltage exceeds maximum rated voltage	1 red	
over-current	The phase current through the motor exceeds the rated current or the phase-to-phase short circuit	2 red	

Missing phase	Position out of tolerance	3 red	
Internal reference error	EEPROM read error	4 red	
Bus current overcurrent	Driver internal fault	5 red	

## 4. DIP SWITCH SETTING

ZLIM42 uses a five-digit dial switch, set the step resolution accuracy and motor rotate direction. The detailed description is as follows:

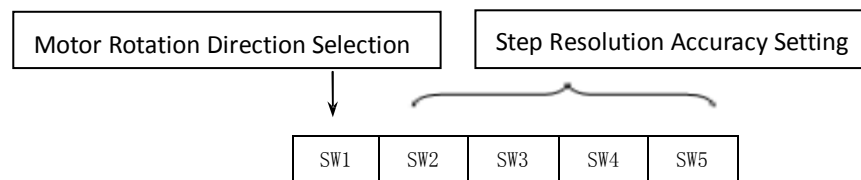

### 4.1. Step resolution Setting

The step resolution parameters can be customized according to customer requirements, ranging from 200 to 25600 Step/Rev. For example, the default is the following table.

SW2	SW3	SW4	SW5	Step/Rev
ON	ON	ON	ON	200
OFF	ON	ON	ON	400
ON	OFF	ON	ON	800
OFF	OFF	ON	ON	1600
ON	ON	OFF	ON	3200
OFF	ON	OFF	ON	6400
ON	OFF	OFF	ON	12800
OFF	OFF	OFF	ON	25600
ON	ON	ON	OFF	1000
OFF	ON	ON	OFF	2000



ON	OFF	ON	OFF	4000
OFF	OFF	ON	OFF	5000
ON	ON	OFF	OFF	8000
OFF	ON	OFF	OFF	10000
ON	OFF	OFF	OFF	20000
OFF	OFF	OFF	OFF	25000

## 4.2. Motor Rotation Direction Setting

SW1=off, the motor rotates counterclockwise (CCW);

SW1=on, clockwise rotation (CW).